



Ośrodek Wspierania Przemysłu

„AKRO-TECH” Monika Piaskowska
70-660 Szczecin, ul. Gdańska 10
NIP: 852-191-80-70; REGON: 12396423

tel. (91) 489 63 62, fax. (91)462 30 00
kom.: 500 189 009

biuro@akro-tech.pl www.akro-tech.pl

CENNIK DETALICZNY

obowiązuje od: Styczeń 2009

TYP: NOŻE TOKARSKIE LUTOWANE
MATERIAŁ: S10, S20, S30, K20, K30, M20
ZASTOSOWANIE: Stale, stale nierdzewne, stale stopowe, staliwa, żeliwa, grafit, inne

Standard		Wielkość (mm)	Długość (mm)	Katalogowa [ZŁ]	Rabat 10% [ZŁ]
Routhing tool - straight ISO 1R ISO 1L NNZa - NNZb DIN 4971		10x10	90	9,67 zł	8,70 zł
		12x12	100	10,38 zł	9,34 zł
		16x16	110	12,81 zł	11,53 zł
		20x20	125	18,29 zł	16,46 zł
		25x25	140	26,89 zł	24,20 zł
		32x32	170	45,71 zł	41,14 zł
		40x40	200	81,83 zł	73,65 zł
		50x50	240	144,59 zł	130,13 zł

Standard		Wielkość (mm)	Długość (mm)		
Routhing tool - bent ISO 2R ISO 2L NNZc - NNZd DIN 4972		10X10	90	10,68 zł	9,61 zł
		12X12	100	11,25 zł	10,13 zł
		16X16	110	13,94 zł	12,55 zł
		20X20	125	18,72 zł	16,85 zł
		25X25	140	26,97 zł	24,27 zł
		32X32	170	45,01 zł	40,51 zł
		40X40	200	87,97 zł	79,17 zł
		50X50	240	157,80 zł	142,02 zł

Standard		Wielkość (mm)	Długość (mm)		
Corner tools ISO 3R ISO 3L NNBc - NNBf DIN 4978		16X10	110	11,64 zł	10,48 zł
		20X12	125	13,01 zł	11,71 zł
		25X16	140	16,73 zł	15,06 zł
		32X20	170	25,22 zł	22,70 zł
		40X25	200	41,57 zł	37,41 zł
		50X32	240	77,35 zł	69,62 zł

Standard		Wielkość (mm)	Długość (mm)		
Necking tools ISO 4 NNPd DIN 4976		20X12	125	13,99 zł	12,59 zł
		25X16	140	20,07 zł	18,06 zł
		32X20	170	29,46 zł	26,51 zł
		40X25	200	47,83 zł	43,05 zł
		50X32	240	86,66 zł	77,99 zł

Standard		Wielkość	Długość	Katalogowa	Rabat 10%
		(mm)	(mm)	[Zł]	[Zł]
Necking tools ISO 5R ISO5L NNBk-NNBm DIN 4977		20X20	125	19,82 zł	17,84 zł
		25X25	140	28,77 zł	25,89 zł
		32X32	170	48,85 zł	43,97 zł
		40X40	200	91,90 zł	82,71 zł
		50X50	240	163,07 zł	146,76 zł

Standard		Wielkość	Długość		
		(mm)	(mm)		
Routhing tool - side ISO 6R ISO 6L NNBe -NNBf DIN 4980		10X10	90	10,66 zł	9,59 zł
		12X12	100	11,38 zł	10,24 zł
		16X16	110	13,94 zł	12,55 zł
		20X20	125	19,23 zł	17,31 zł
		25X25	140	27,80 zł	25,02 zł
		32X32	170	46,48 zł	41,83 zł
		40X40	200	88,53 zł	79,68 zł
50X50	240	156,67 zł	141,00 zł		

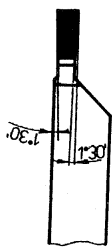
Standard		Wielkość	Długość		
		(mm)	(mm)		
Necking tools ISO 7R ISO 7L NNPa - NNPC DIN 4981		12X8	100	10,32 zł	9,29 zł
		16X10	110	13,01 zł	11,71 zł
		20X12	125	13,42 zł	12,08 zł
		25X16	140	17,31 zł	15,58 zł
		32X20	170	26,04 zł	23,44 zł
		40X25	200	45,41 zł	40,87 zł
		50X32	240	71,57 zł	64,41 zł

Standard		Wielkość	Długość		
		(mm)	(mm)		
Internal routhing tools ISO 8R ISO8L NNWa - NNUa DIN 4973		8X8	125	14,92 zł	13,43 zł
		10X10	150	15,37 zł	13,83 zł
		12X12	180	14,05 zł	12,65 zł
		16X16	210	16,45 zł	14,81 zł
		20X20	250	22,51 zł	20,26 zł
		25X25	300	36,15 zł	32,54 zł
		32X32	355	64,01 zł	57,61 zł

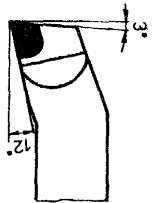
Standard		Wielkość	Długość		
		(mm)	(mm)		
Internal corner tools ISO 9R ISO9L NNWb - NNUb DIN 4974		8X8	125	15,13 zł	13,62 zł
		10X10	150	15,55 zł	14,00 zł
		12X12	180	14,89 zł	13,40 zł
		16X16	210	17,48 zł	15,73 zł
		20X20	250	23,26 zł	20,93 zł
		25X25	300	36,87 zł	33,18 zł
		32X32	355	64,56 zł	58,10 zł

Standard		Wielkość	Długość	Katalogowa	Rabat 10%
Smoothing tools ISO 10 NNPe DIN 4975		(mm)	(mm)	[Zł]	[Zł]
		16X10	110	10,38 zł	9,34 zł
		20X12	125	12,17 zł	10,95 zł
		25X16	140	15,26 zł	13,73 zł
		32X20	170	23,19 zł	20,87 zł
		40X25	200	35,95 zł	32,36 zł

Standard		Wielkość	Długość		
Necking tools - internal ISO 11 NNWc DIN 263		(mm)	(mm)		
		12X12	150	20,73 zł	18,66 zł
		16X16	180	26,00 zł	23,40 zł
		20X20	210	33,93 zł	30,54 zł
		25X25	250	48,44 zł	43,60 zł
		32X32	300	80,45 zł	72,41 zł

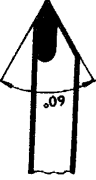
Standard		Wielkość	Długość		
Threading tools - external ISO 12R ISO 12L NNGc - NNGr DIN 282		(mm)	(mm)		
		16X10		12,81 zł	11,53 zł
		20X12	125	15,23 zł	13,71 zł
		25X16	140	19,61 zł	17,65 zł
		32X20	170	29,88 zł	26,89 zł

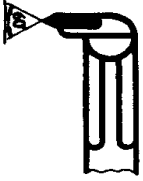
Standard		Wielkość	Długość		
Threading tools - interna ISO 13R ISO13L NNGd - NNGs DIN 283		(mm)	(mm)		
		10X10	125	19,82 zł	17,84 zł
		12X12	150	21,58 zł	19,42 zł
		16X16	180	26,55 zł	23,90 zł
		20X20	210	34,16 zł	30,74 zł
		25X25	250	49,35 zł	44,42 zł
		32X32	300	77,96 zł	70,16 zł



Ośrodek Wspierania Przemysłu

„AKRO-TECH” Monika Piaskowska
70-660 Szczecin, ul. Gdańska 10
NIP: 852-191-80-70; REGON: 12396423

tel. (91) 489 63 62, fax. (91)462 30 00
kom.: 500 189 009

biuro@akro-tech.pl www.akro-tech.pl

CENNIK CETALICZNY

obowiązuje od: Styczeń 2009

TYP: NOŻE TOKARSKIE ZE STALI SZYBKOTNĄCEJ
MATERIAŁ: SW7M, SK5
ZASTOSOWANIE: Stale, stale nierdzewne, stale stopowe, staliwa, żeliwa, grafit, inne

Standard		Wielkość (mm)	Długość (mm)	Katalogowa [Zł]	Rabat 5% [Zł]
Routhing tool - straight NNZa - NNZb		10x10	90	21,39 zł	20,32 zł
		12x12	100	38,20 zł	36,29 zł
		16x16	110	49,18 zł	46,72 zł
		20x20	125	61,00 zł	57,95 zł
		25x25	140	90,93 zł	86,38 zł

Standard		Wielkość (mm)	Długość (mm)		
Routhing tool - bent NNZc - NNZd		10X10	90	25,59 zł	24,31 zł
		12X12	100	28,73 zł	27,29 zł
		16X16	110	39,37 zł	37,40 zł
		20X20	125	56,28 zł	53,47 zł
		25X25	140	89,54 zł	85,06 zł

Standard		Wielkość (mm)	Długość (mm)			
Corner tools NNBc - NNbf		16X10	110	35,44 zł	33,67 zł	
		20X12	125	44,79 zł	42,55 zł	
		25X16	140	63,92 zł	60,72 zł	
		32X20	170	97,06 zł	92,21 zł	

Standard		Wielkość (mm)	Długość (mm)		
Necking tools NNPd		20X12	125	33,66 zł	31,98 zł
		25X16	140	49,11 zł	46,65 zł
		32X20	170	81,01 zł	76,96 zł

Standard		Wielkość (mm)	Długość (mm)	Katalogowa	Rabat 5%
Routhing tool - side NNBe - NNBF		10X10	90	23,59 zł	22,41 zł
		12X12	100	26,60 zł	25,27 zł
		16X16	110	40,35 zł	38,33 zł
		20X20	125	56,86 zł	54,02 zł
		25X25	140	93,98 zł	89,28 zł

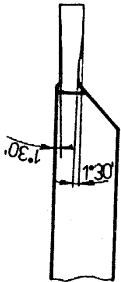
Standard		Wielkość (mm)	Długość (mm)		
Necking tools NNPa - NNPC		12X8	100	19,34 zł	18,37 zł
		16X10	110	20,42 zł	19,40 zł
		20X12	125	23,90 zł	22,71 zł
		25X16	140	32,83 zł	31,19 zł
		32X20	170	48,93 zł	46,48 zł
		40X25	200	82,33 zł	78,21 zł

Standard		Wielkość (mm)	Długość (mm)		
Internal routhing tools NNWa - NNua		8X8	125	21,26 zł	20,20 zł
		10X10	150	23,09 zł	21,94 zł
		12X12	180	23,81 zł	22,62 zł
		16X16	210	38,63 zł	36,70 zł
		20X20	250	60,13 zł	57,12 zł
		25X25	300	103,20 zł	98,04 zł

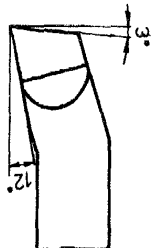
Standard		Wielkość (mm)	Długość (mm)		
Internal corner tools NNWb - NNub		8X8	125	21,64 zł	20,56 zł
		10X10	150	23,50 zł	22,33 zł
		12X12	180	23,78 zł	22,59 zł
		16X16	210	40,53 zł	38,50 zł
		20X20	250	64,64 zł	61,41 zł
		25X25	300	103,03 zł	97,88 zł
		32X32	355	126,01 zł	119,71 zł

Standard		Wielkość (mm)	Długość (mm)	[Zł]	[Zł]	
Smoothing tools NNPe		16X10	110	26,88 zł	25,54 zł	
		20X12	125	33,24 zł	31,58 zł	
		25X16	140	49,25 zł	46,79 zł	
		32X20	170	81,94 zł	77,84 zł	

Standard		Wielkość	Długość	Katalogowa	Rabat 5%
Necking tools - internal NNWc		(mm)	(mm)		
		12X12	150	36,21 zł	34,40 zł
		16X16	180	49,83 zł	47,34 zł
		20X20	210	68,48 zł	65,06 zł
		25X25	250	101,28 zł	96,22 zł
		32X32	300	168,58 zł	160,15 zł

Standard		Wielkość	Długość		
Threading tools - external NNGc - NNGr		(mm)	(mm)	[Zł]	
		16X10		31,96 zł	30,36 zł
		20X12	125	40,15 zł	38,14 zł
		25X16	140	66,43 zł	63,11 zł
		32X20	170	99,69 zł	94,71 zł

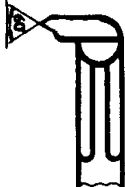
Standard		Wielkość	Długość		
Threading tools - interna NNGd - NNGs		(mm)	(mm)		
		12X12	150	53,01 zł	50,36 zł
		16X16	180	64,43 zł	61,21 zł
		20X20	210	86,33 zł	82,01 zł
		25X25	250	110,41 zł	104,89 zł

NOŻE DŁUTOWNICZE

Standard		Wielkość	Szerokość	Katalogowa	Rabat 3%
NNDf		(mm)	(mm)		
		16X16	3	160,69 zł	155,87 zł
		16X16	4	161,29 zł	156,45 zł
		20X20	5	175,84 zł	170,56 zł
		20X20	6	177,92 zł	172,58 zł
		25X25	7	205,44 zł	199,28 zł
		25X25	8	213,38 zł	206,98 zł
		30X30	10	306,98 zł	297,77 zł
30X30	12	307,88 zł	298,64 zł		

Dłuższy czas realizacji